

USPS EXPRESS

EMRR 2009
BOX O' PARTS
ENTRY

UNITED STATES POSTAL SERVICE

*... In the year 2055,
Piracy has moved from the
deep seas to deep space.
... Rouge Pirate Ships now attack
and pillage Mail Carrier Ships
delivering letters and cargo
from Earth to newly settled
Space Stations and Planets.
The new Space Mail Carriers are now
armed and ready for any conflict.*

**"Neither Pirate nor Deep Space or Asteroid's Hail,
Nothing Stops the U.S. Mail!"**

Entry submitted by Hans "Chris" Michielssen

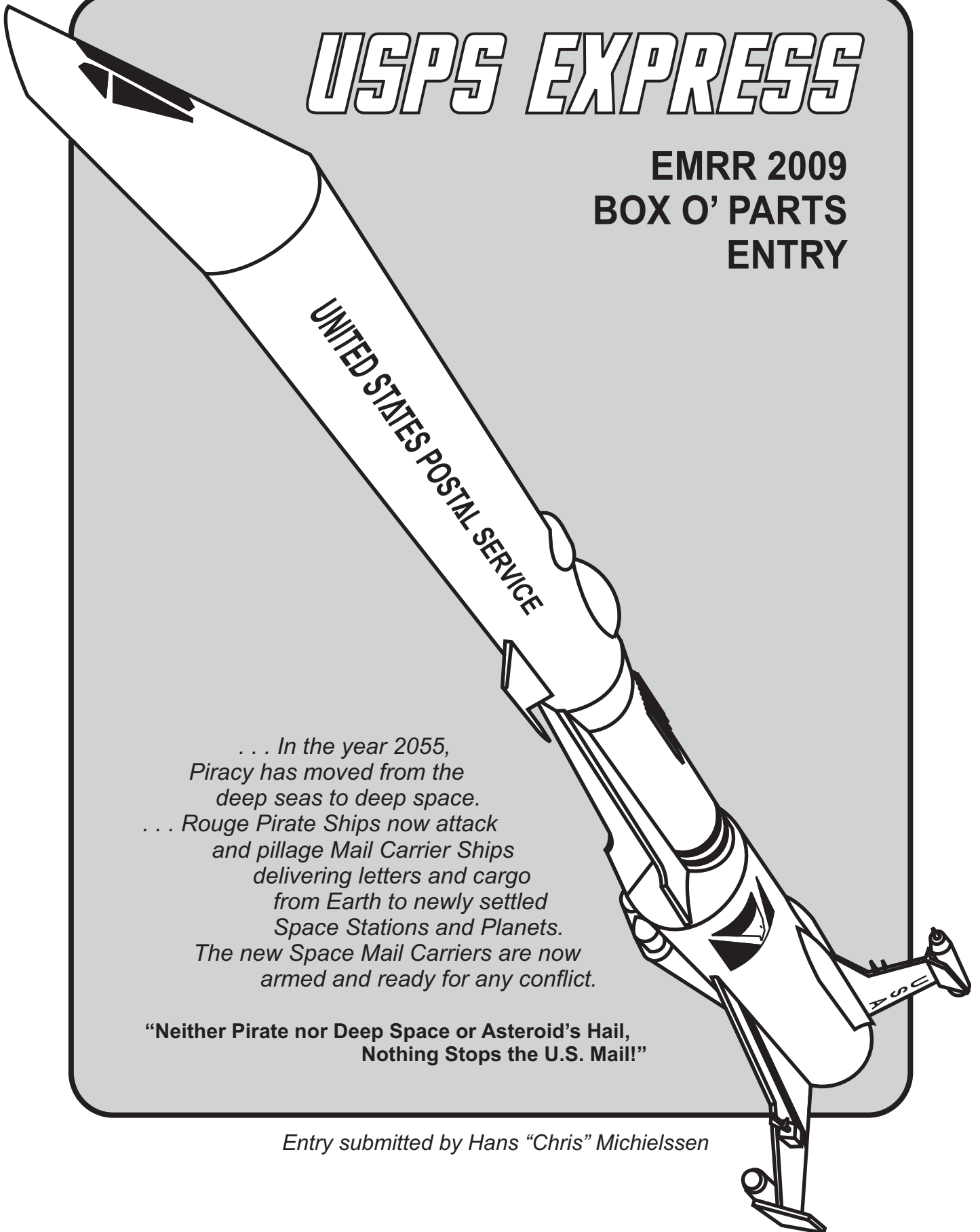

USPS EXPRESS

2009 BOX O' PARTS ENTRY by Hans "Chris" Michielssen

Here's the parts I received when all laid out:

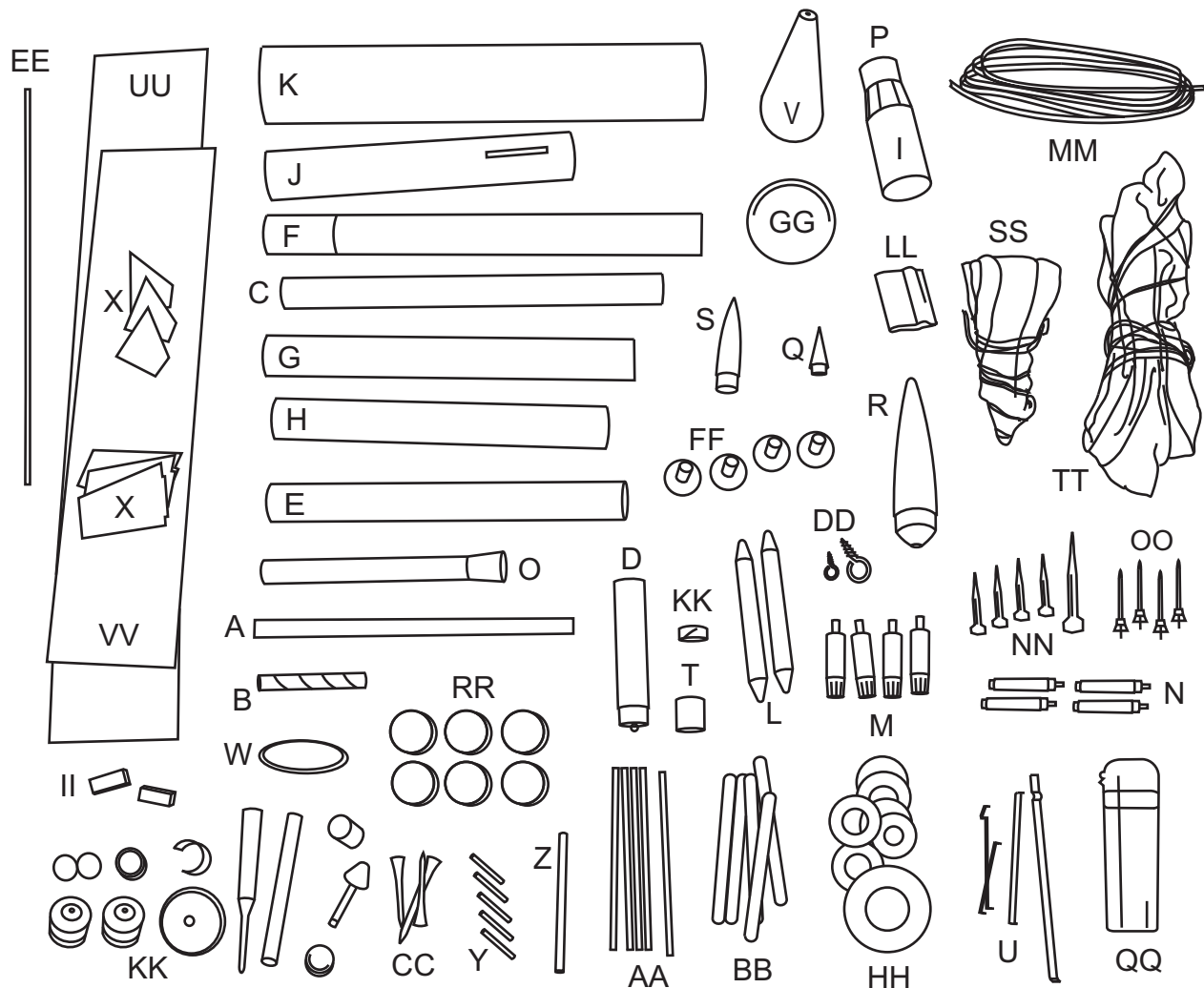

PARTS LIST:

A	BT-5	12" long	N	4 BT-3 Pod assemblies 2" long each
B	BT-5 size	3 1/2" long party horn tube	O	20/50 Balsa Transition adapter
C	BT-20	14 1/2" long	P	55/60 Plastic Transition Adapter
D	BT-50	4" Clear Tube	Q	Balsa Conical Nose Cone for BT-5
E	BT-50	12 1/2" long	R	Plastic Nose Cone for BT-55
F	BT-55	14" long	S	Balsa Nose Cone for BT-20
G	BT-56	11" long	T	2 (Usable) BT-50 Balsa Blocks
H	BT-55	12" long	U	4 Engine Hooks (different sizes)
I	BT-60	3" long	V	"Street Marker" Conical Cone, 2" at base
J	BT-60	10 1/2" long	W	1 Clear Plastic "Half" Bubble 2 1/2" long
K	BT-80	15 long	X	6 "Pre-cut balsa Fins
L	2 BT-5 "Pod" assemblies	5" long each (nose cones glued in each end)	Y	5 Launch Lugs 1/8" X 1"
M	4 Bt-5 Nozzles assemblies	2 1/4" long each	Z	1 Launch Lug 3/16" X 4"

AND MORE PARTS:

R	Plastic Nose Cone for BT-55	HH	Various Fiber Centering Rings
S	Balsa Nose Cone for BT-20	II	2 Black Plastic "Angle" Pieces
T	2 (Usable) BT-50 Balsa Blocks	JJ	1 20 size Engine Block
U	4 Engine Hooks (different sizes)	KK	10 Various Plastic "Tips, ends and points"
V	"Street Marker" Conical Cone, 2" at base	LL	Orange Plastic Streamer 54" X 2"
W	1 Clear Plastic "Half" Bubble 2 ½" long	MM	3/8" wide Black Shock Cord - LONG!
X	6 "Pre-cut balsa Fins	NN	5 small plastic "Missiles"
Y	5 Launch Lugs 1/8" X 1"	OO	4 White plastic Star Wars guns
Z	1 Launch Lug 3/16" X 4"	PP	8 small orange plastic "Tips"
AA	4 Cardstock Tubes, 3/16" X 5 ½"	QQ	1 Plastic Candy Container
BB	5 Popsicle Sticks	RR	6 plastic "Plugs" Many holed
CC	3 Golf Tees	SS	24" Nylon Parachute
DD	Snap Swivel & 2 Screw eyes	TT	36" Nylon Parachute
EE	1 Bamboo Skewer 5 ½" long	UU	1 sheet Basswood 1/8" X 4" X 24"
FF	4 Black Plastic "Landing Feet"	VV	1 sheet Basswood 1/8" X 4" X 16"
GG	1 Yellow Plastic Dome 3" diameter		

INITIAL VISIONS:

With so many small, decorative pieces sent, it made the best sense to build a Sci-Fi Fantasy Spaceship.

There almost seems to be too many parts in the box! Rather than just gluing everything to the main tube, I'll try to combine as many (recognizable) parts into sub-assemblies and then attach them to the model.

I first visualized the body tubes, adapter and nose cone together, laid out on the floor.

The large diameter "engine compartment" (K) will connect to the trimmed Yellow Plastic Dome (GG).

Larger coolant "vaness" (UU) will be cut to fit the dome and tube transition.

Two BT-55s (F and H) would be joined together, housing the engine mount. These BT-55s are also the offset Stuffer tube extending forward out of the dome. (GG)

Next is the Plastic 55/60 adapter.(P) The inside ends will be trimmed and coated with epoxy to protect the plastic interior from the ejection charge.

The adapter connects to the BT-60.(J) This larger diameter tube will be used on the top to accommodate a supplied 24" parachute. (SS)

The "Street Marker Conical Cone" (V) will top off the model. It'll require heavy filling and trimming to work.

I re-drew the model for a third time. I played with variations and came up with "Butterflied" Rudder tips. The wings will have down turned wing tips. "Engines" (M, N & A) will fit into the angle formed by the wing tips.

While initially I had other plans for a different name and decor, uncooperative decals led me to the finished design: The USPS Express.

I'll build all the sub-assemblies first, then assemble everything.

PRE AND SUB ASSEMBLIES

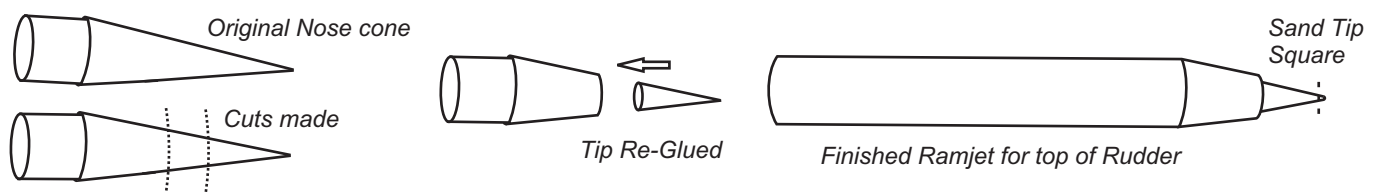

1. RUDDER RAM-JET: A ram-jet style nose cone was made out off part Q. I cut ½" off the tip with a razor saw then sanded the cuts flat with a sanding block. More sanding followed until it achieved the right visual balance. This will be joined to a shortened BT-5 (A) and be glued to the middle of the rudder's butterflyed top.

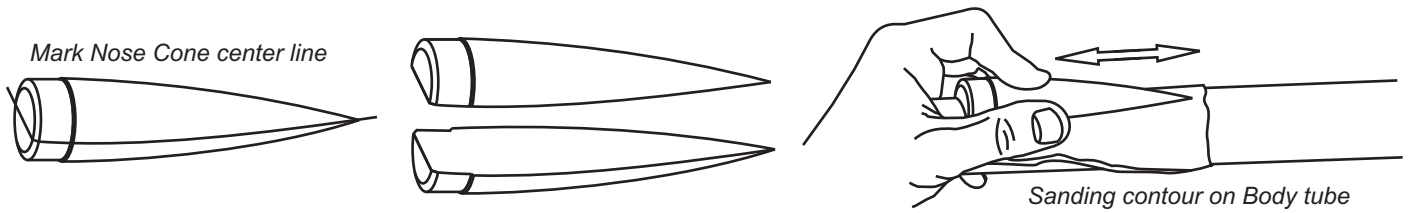

2. SIDE OF RUDDER FAIRINGS: The balsa cone (S) was split down the middle, then sanded to the contour of a BT-60. These will be used to make side engine intakes on both sides of the rudder. The BT-20 (C) was split lengthwise down the middle to fit the two sides from the split nose cone.

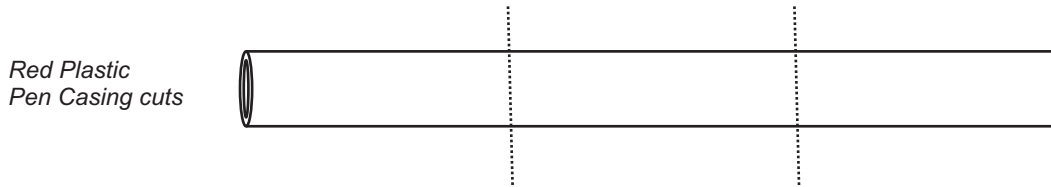

3. ENGINE EXHAUST TUBES: The Red plastic Sanford Pen Casing (KK) was cut into thirds. Two will be centered in the front of the wing engine assemblies. The remaining third piece will go out the end of the rudder tube.

The BT-5 (A) was also cut into thirds, all three pieces are 4" long.

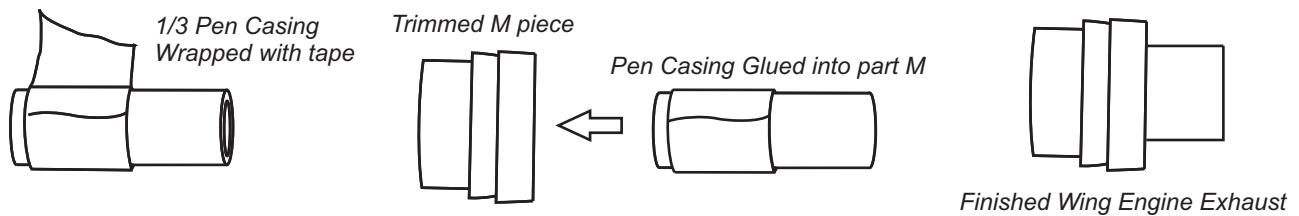

4. WING ENGINE EXHAUST: I will use the four white plastic engine nacelles on either side of the engine tubes. Trim two Part M pieces to the profile shown. (The other two M pieces are left long.) Masking tape is wrapped around the 1/3 pen casing to friction fit in the trimmed engine front.

The pen casing was glued into the engine intake. The intake is glued into one of the three BT-5s. Repeat with the another M piece and BT-5 tube.

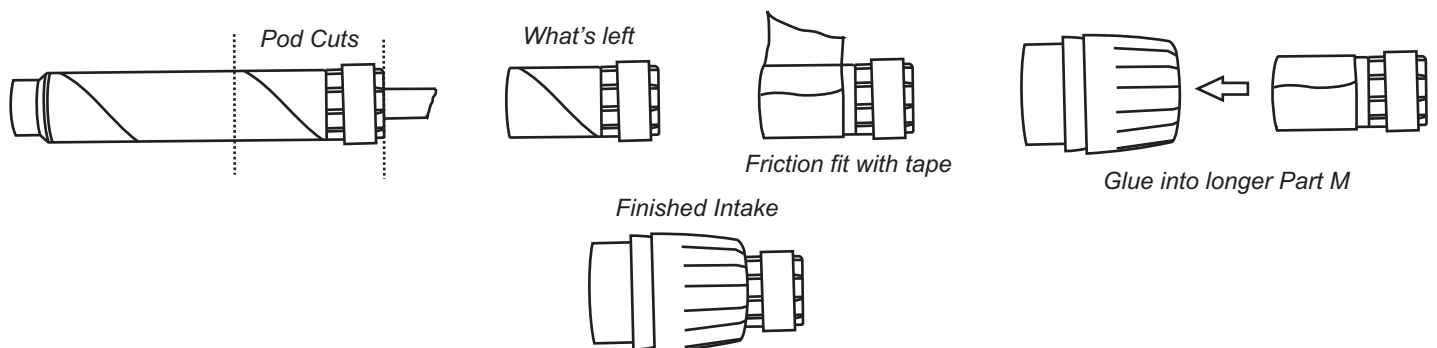

5. WING ENGINE INTAKES: Cut the smaller BT-3 pod assemblies (N) as shown. Wrap with body tube side with tape to fit the longer, remaining BT-5 Nozzles. (M) Glue the trimmed pod assembly into the BT-5 Nozzle. Make another intake with the remaining pieces.

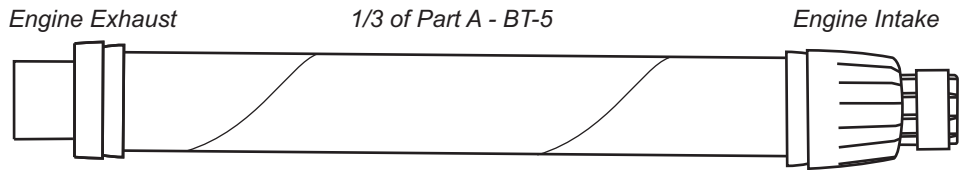

6. Glue an intake assembly into one of the cut BT-5 tubes. Glue an exhaust assembly into the other end. Repeat with the remaining BT-5 piece, intake and exhaust assemblies.

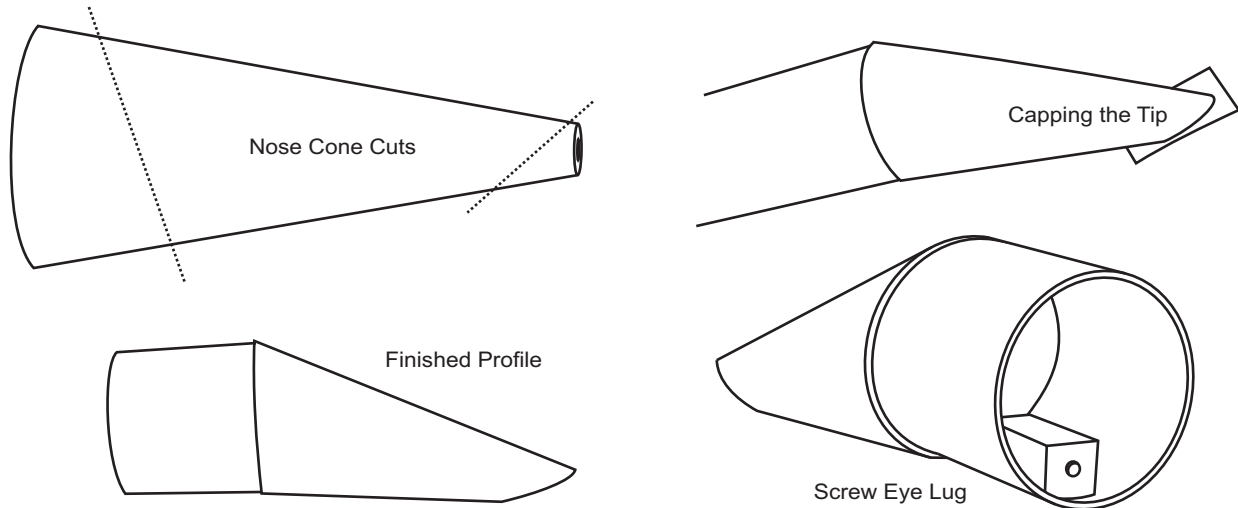

7. THE NOSE CONE (V): Cuts were made with a razor saw along the lines as shown. A piece of scrap body tube was glued on the flat tip cut. The excess was trimmed and sanded flush.

A coupler was made from 1 1/2" of scrap BT-60 the same way as the BT-55 coupler made earlier. It is centered and glued against the nose cone shoulder. Forward of the shoulder joint the Nose Cone was entirely filled with clay and three dimes ("Surprise Parts Bonus") for extra nose weight and stability.

A Screw Eye "lug" block was made from three laminations of the 1/8" basswood. The block was glued in place and drilled for a screw eye. (DD)

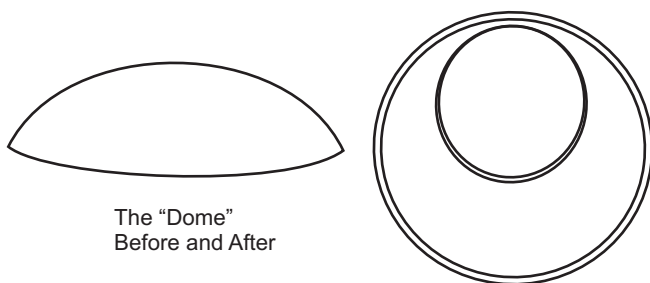

8. "THE DOME": Cutting out the Dome is really trial and error. No template is provided as there would be no way to mark the curved surface.

Trace around the BT-55 (outside diameter) near the top. As you cut out the hole, picture the BT-55's angle of exit and taper the hole to that angle.

After the hole is cut, then trace the BT-80 (outside diameter) around the dome. Trim and sand to fit the BT-80.

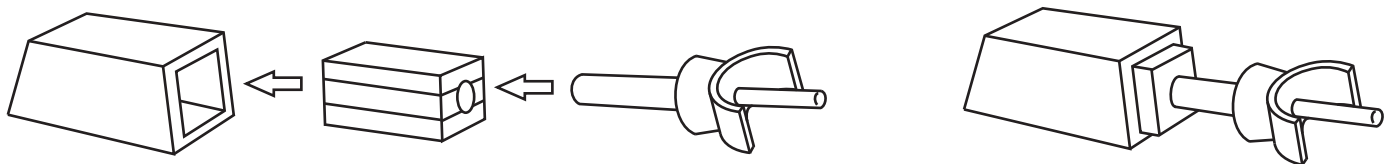

9. WING GUNS: Three pieces of laminated 1/8" basswood (UU) are trimmed to fit inside the Black Angle Piece. (II) The block extends out the front of the Black Angle Piece by 1/16". The Basswood block is drilled to fit the diameter of the White Plastic Star Wars Guns. (OO) All three parts are glued

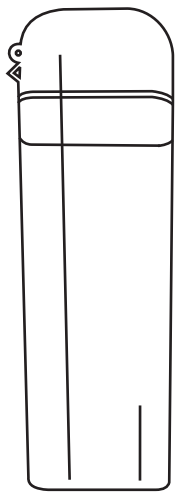

Candy Container (QQ)
Discard the Red Top



BT-5 "Pod" Assemblies (L)
Cut at line, save short end

Sanding the Container (QQ)
against 150 Grit Sandpaper
wrapped around the BT--80.
Sand the BT-5 Pods the same way

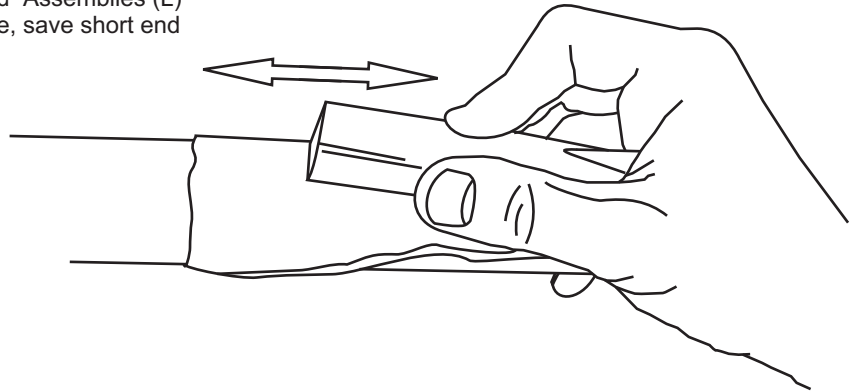

10. UNDERBODY INTAKE FAIRING: Remove and discard the top of the Candy Container. (QQ) Sand the bottom of the container against the BT-80 tube with 150 grit sandpaper. Sand until the rear is completely removed and you are left with the shape below.

Cut the BT-5 "Pods" (L) off at 1 1/16" from the tip of the nose cones. (The nose cones were already glued in place.) Sand the contour against the body tube the same way as you did the candy container.

Glue the cut "Pods" to the flat front of the prepared candy container. The completed fairing will be glued to the bottom of the BT-80, on the line, centered directly under the rudder. The rear of the fairing is 6" from the rear of the BT-80.

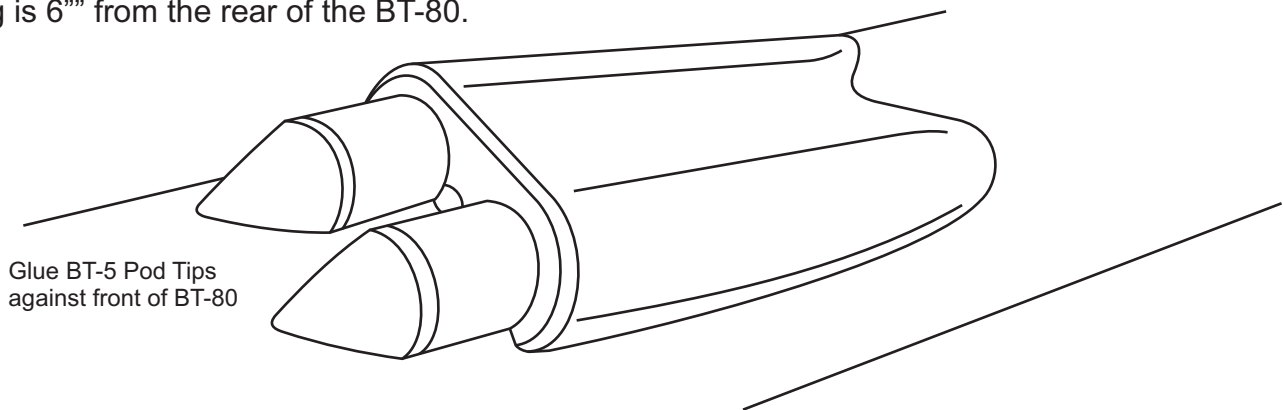

Glue BT-5 Pod Tips
against front of BT-80

11. ADDITIONAL TRIM "DOMES": Sand the Clear Plastic Half Bubbles (W & KK) against the BT-60 body tube. Sand the same way as the Candy Container in the previous step.

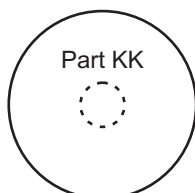

Side curvatures
after sanding



***SUB-ASSEMBLIES
ARE FINISHED!
ON TO THE
MAIN ASSEMBLY . . .***

PUTTING IT ALL TOGETHER:

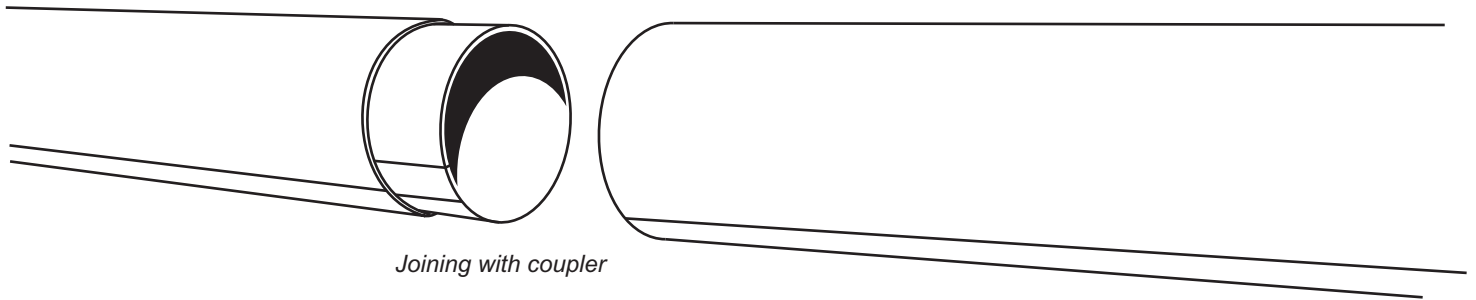

12. MAIN (INTERIOR) BODY TUBE: 1 1/4" was cut off the BT-56 (G) to make a coupler. It is split lengthwise and slid it into the BT-55. (F) The overlap is marked, then trimmed it to fit snugly. It will take some "shimming" to make these two (close diameter) tubes fit. (F & H) The butt-joint will be hidden under the rear BT-80 (K) tubing.

13. ENGINE MOUNT: The model will fly with a D12-5 fitting into a BT-50 motor mount tube. (Part E)

A 3" piece of BT-50 was cut for an engine mount tube. The BT-50 was notched for the supplied engine hook.(U) The end of the hook extended 1/4" beyond the engine mount tube.

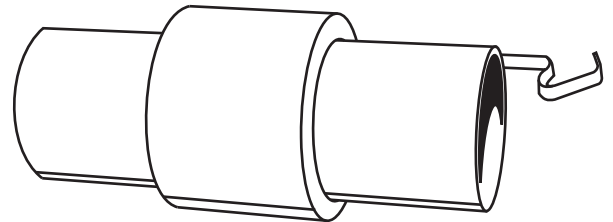

14. CENTERING RINGS: There was plenty of centering rings but no 50/55 rings. From the shipping box, I made a 1" wide centering ring. I kept wrapping the cardboard strip round until it made a slip fit into the BT-55 stuffer tube. I'll lay white glue to plug the open holes in the corrugated cardboard.

The engine mount was glued inside the joined, long BT-55 tube until the BT-50 engine tube was even with the rear of the 55 tube.

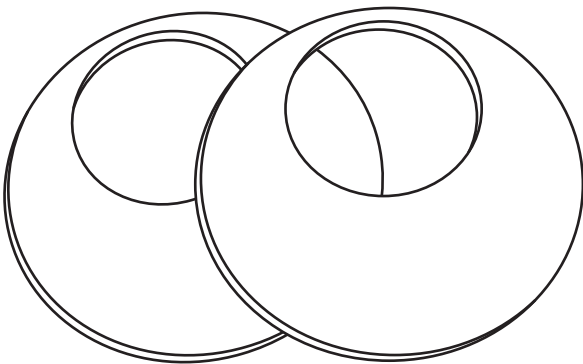

15. Two centering rings were cut out of the shipping box for the stuffer tube inside the rear Bt-80 tube. The interior BT-55 tube is offset to the top of the BT-80. The full-size template is found on the pattern sheet. Draw the vertical lines on both sides of the rings.

16. Cut out the BT-80 Cutting and Marking guide from the pattern sheet. Wrap around the end of the BT-80 and draw around the curved line. At the same time mark the Rudder and Wing positions.

Extend the Rudder line all the way down the BT-80. On the bottom of the guide, mark a line where the ends of the guide meet. Extend that line all the way down the BT-80.

Cut on the curved line, through the BT-80 with a sharp knife.

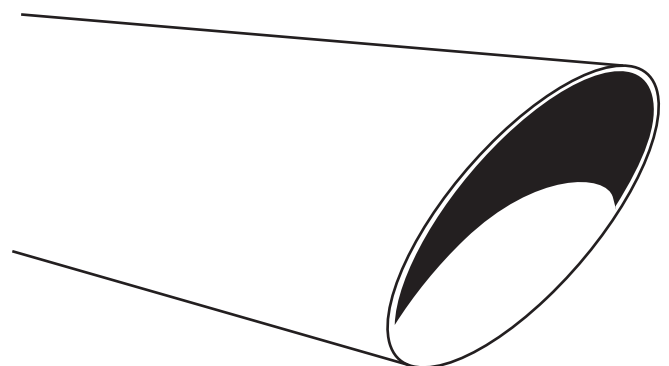

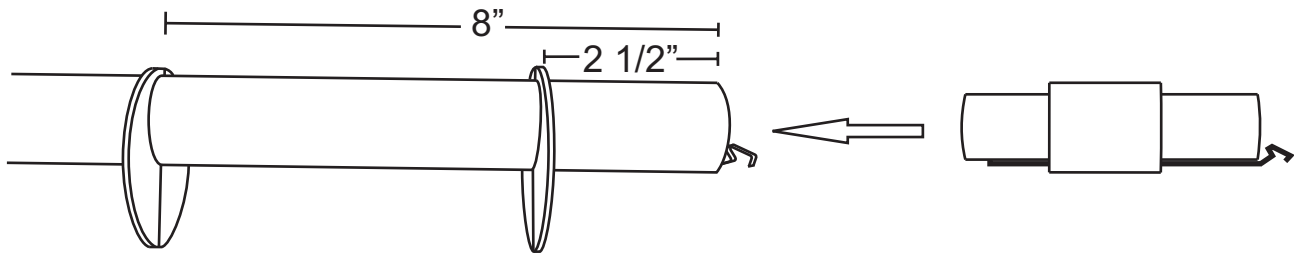

17. REAR ENGINE MOUNT AND CENTERING RINGS: Glue the engine mount in the rear of the BT-55 main tube. Apply a bead of white glue 2" inside the main tube. Slide the mount into the tube until the BT-50 engine tube is even with the end of the BT-55. The engine hook will extend beyond the end of both tubes.

Draw a pencil mark directly beneath the engine hook. Draw another mark directly opposite on the other side of the tube. Extend this line down the entire length of the BT-55 tube. These lines will help position the centering rings and engine vanes.

Glue the offset centering rings at the positions shown. The upper ring is glued 8" from the rear. The lower ring is glued 2 1/2" from the rear. Be sure the lines on the body tube and the vertical lines on the centering rings all line up.

BT-80 CROSS SECTION VIEW

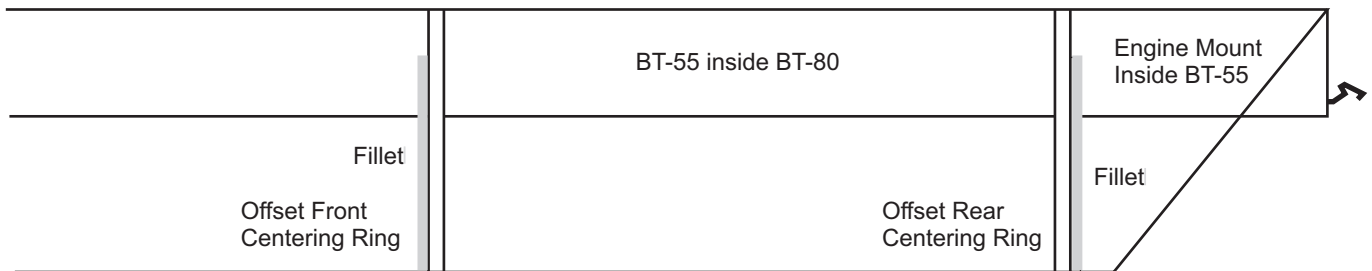

18.

BT-55 AND ENGINE MOUNT PLACEMENT: With the angle cut made in the BT-80, study the drawing above. Slide the entire BT-55 and Engine Mount assembly inside the BT-80. Sand the centering rings if necessary to achieve a sliding, smooth fit.

Be sure the line on top of the BT-55 is even with the Rudder line on the top of the BT-80. The engine hook is directly opposite (down) from the rudder line.

After all is in place, apply a white glue fillet to the rear centering ring from the back of the model. Apply a fillet from the front of the BT-80. The grey boxes indicate the fillet areas. The Front fillet was applied drop by drop with a rounded dowel.

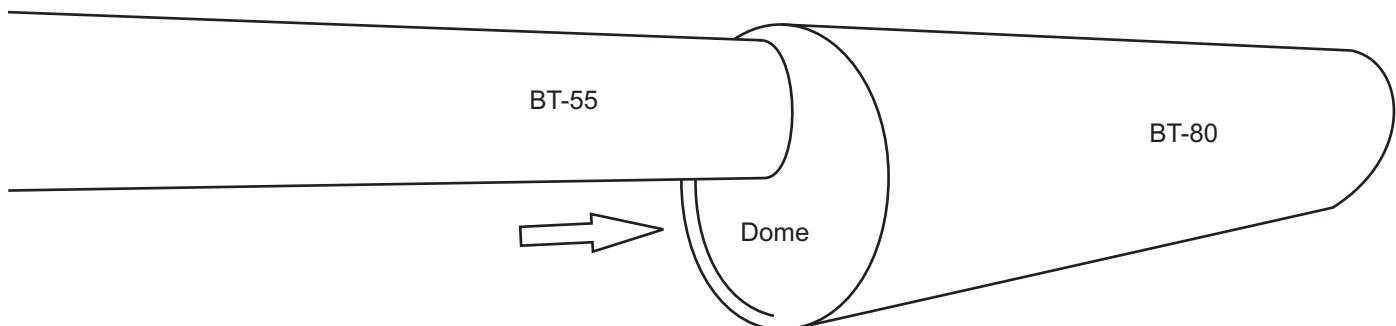

Slide the dome down the BT-55 until it butts -up against the BT-80. Sand and trim if necessary.

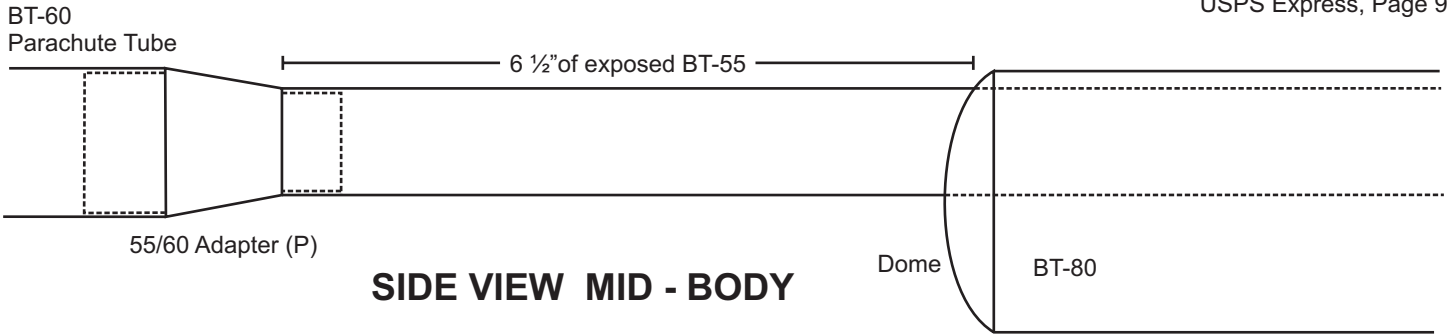

19. Coat the inside of the 55/60 Plastic Adapter (P) with Epoxy to protect the plastic from the ejection charge.

Cut the BT-55 (extending from the Dome) to 6 1/2".

Glue the 55/60 Adapter (P) to the BT-55 with CA glue.

Cut the BT-60 (J) to 10 1/4" long. Glue it to the 55/60 adapter with CA glue.

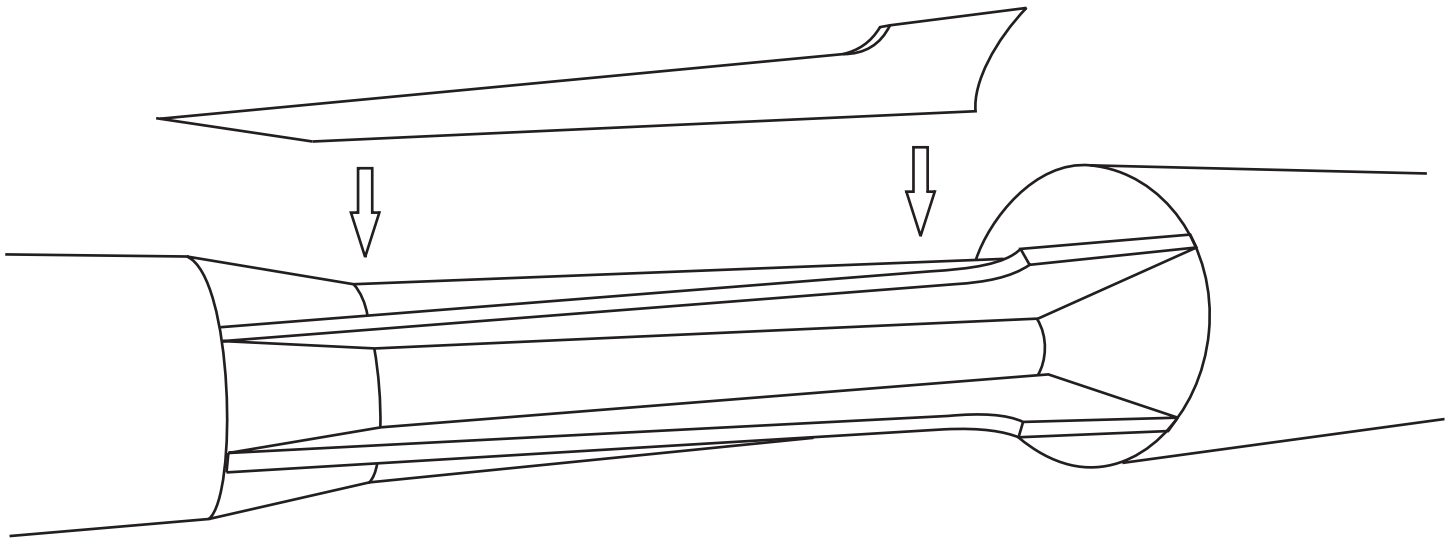

20. UNDERBODY VANES: Cut out the BT-55 Marking Guide from the Pattern Sheets. Wrap it around the BT-55 tube lining up the Center Vane line with the Lower Center Line marked on the BT-80. Mark and extend the lines down the BT-55 tube.

Cut out one Center Vane from the 1/8" Basswood. Cut Two Side Vanes from 1/8" Basswood.

The Basswood vanes will require trimming and sanding to fit the contours of the Dome, Body Tube and Adapter.

Glue the Vanes on their proper lines and Fillet with White Glue.

21. WINGS, RUDDERS AND TIPS: Using the patterns, cut out two Wings and one Rudder. (The Rudder is smaller than the Wings.)

Cut out two Wing Tips and two Rudder "V" Tips.

Using a sanding block, sand the top of the Rudder to the profile shown on the Pattern Sheet. This sanded top edge will give you the correct angle to glue on the "V" tips.

Drill the holes in the leading edge of the Rudder for the Toothpick "Guns".

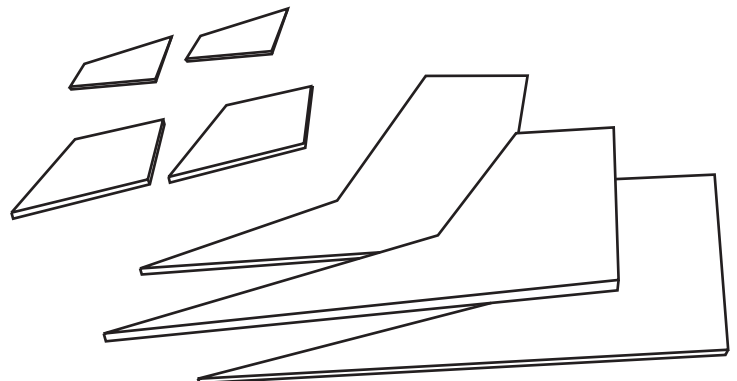

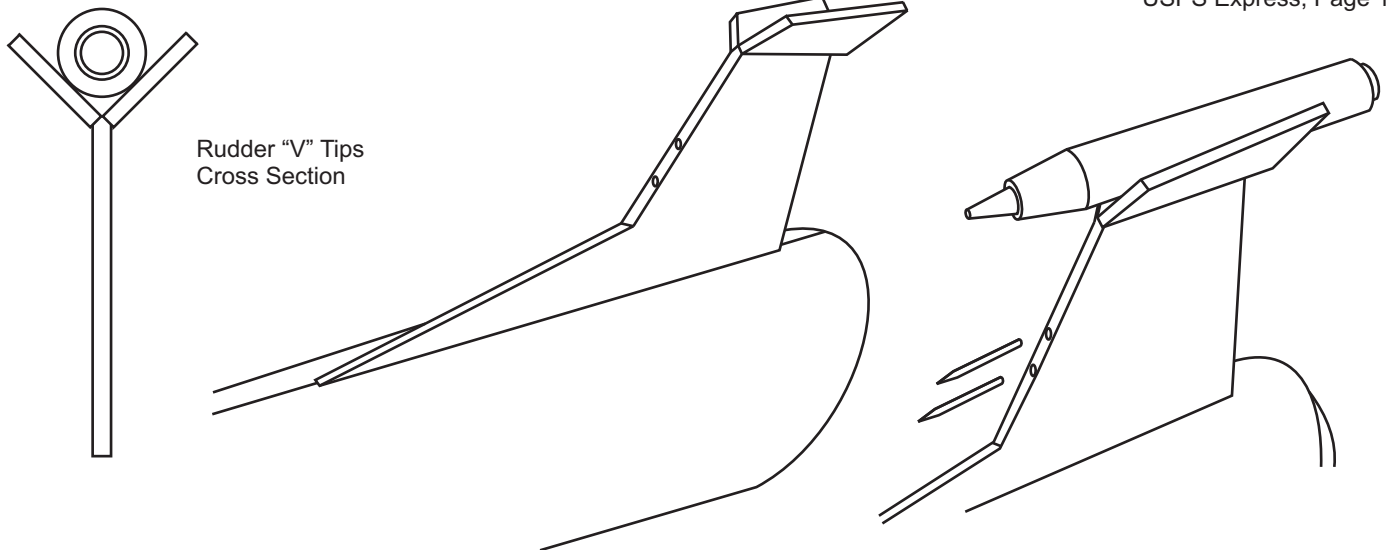

- 22. RUDDER ASSEMBLY:** Glue the Rudder to the centerline 3/4" back from the rear of the BT-80. Glue the Rudder "V" Tips to the top of the Rudder. The "V" Tips should be at a 45 degree angle to the Rudder. After the glue dries, center and glue the Ramjet assembly between the "V" Tips. Glue two 1" Toothpicks in the Rudder's leading edge.

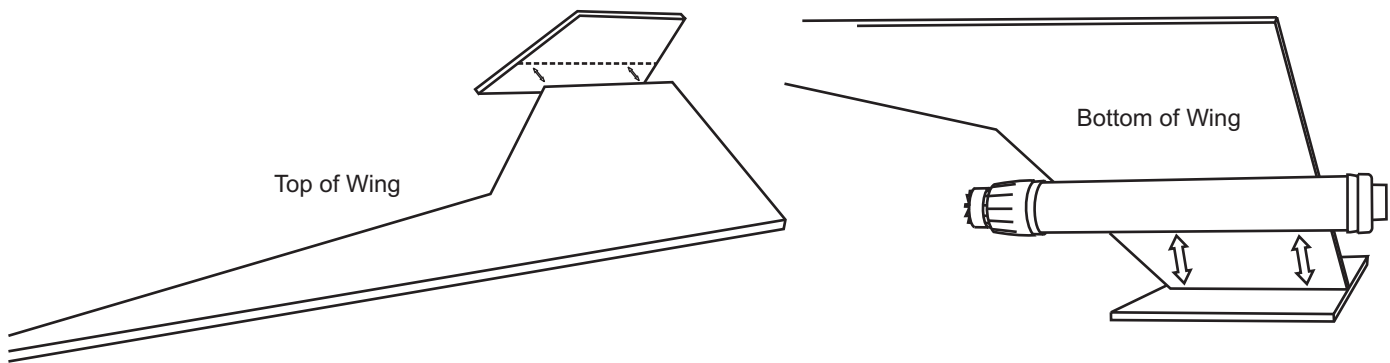

- 23. WING ASSEMBLY:** Glue the Wing on the Wing Line even with the end of the BT-80 . The trailing edge is even with the back of the BT-80. (Not illustrated.) Glue the Wing Tip to the Wing. Allow to dry. Glue the Engine Assembly to the bottom of the Wing, centered and against the Wing Tip.

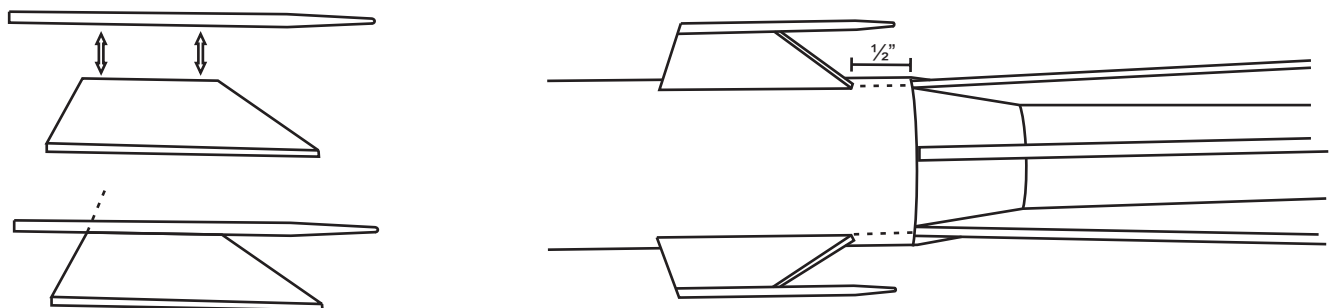

- 24. FORWARD WINGS:** Cut out the Forward Wings from the Pattern Sheets. Cut two Toothpicks oversize and glue in place. Trim to the forward edge of the Wing after it dries. Glue the finished Forward Wings on the BT-60. Position the trailing edge one inch in front of - and in line with the outside Vanes.

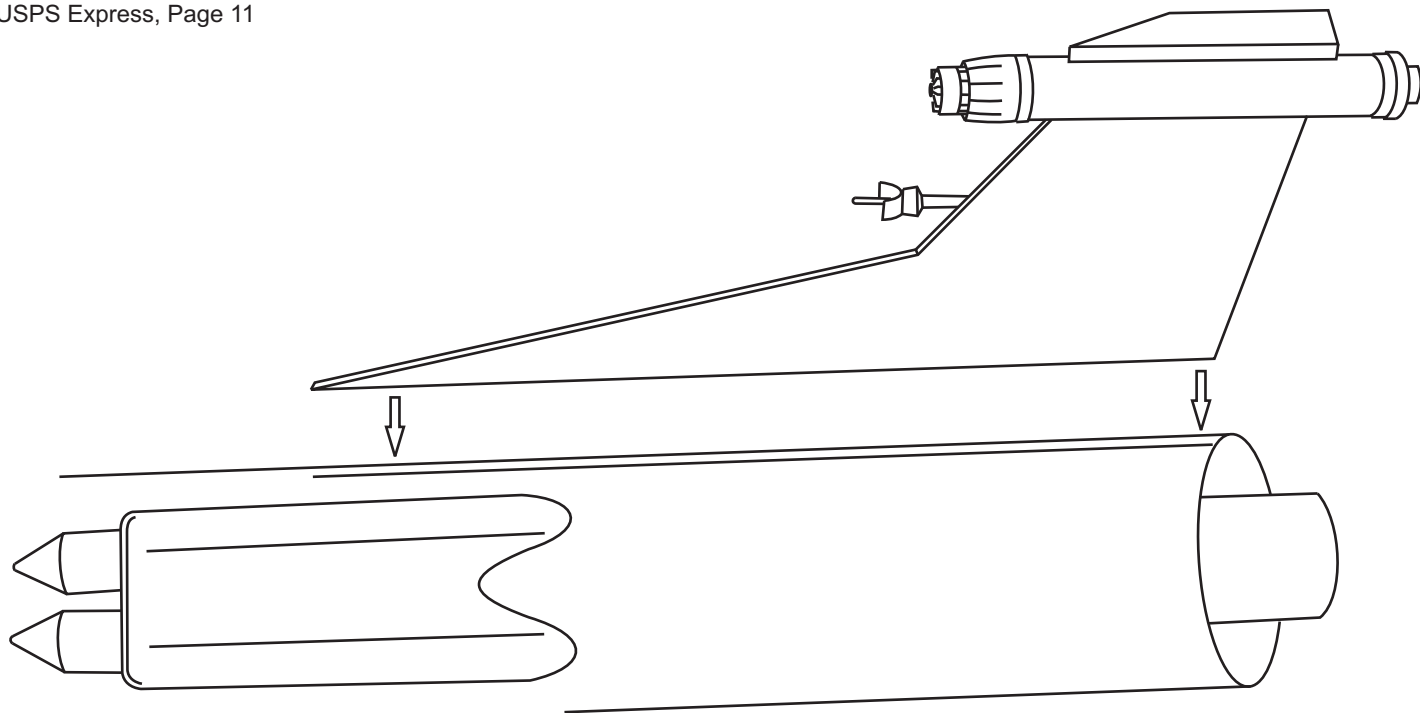

25. Glue the main wing assembly to the body tube, even with the back of the tube. Repeat with the other wing.

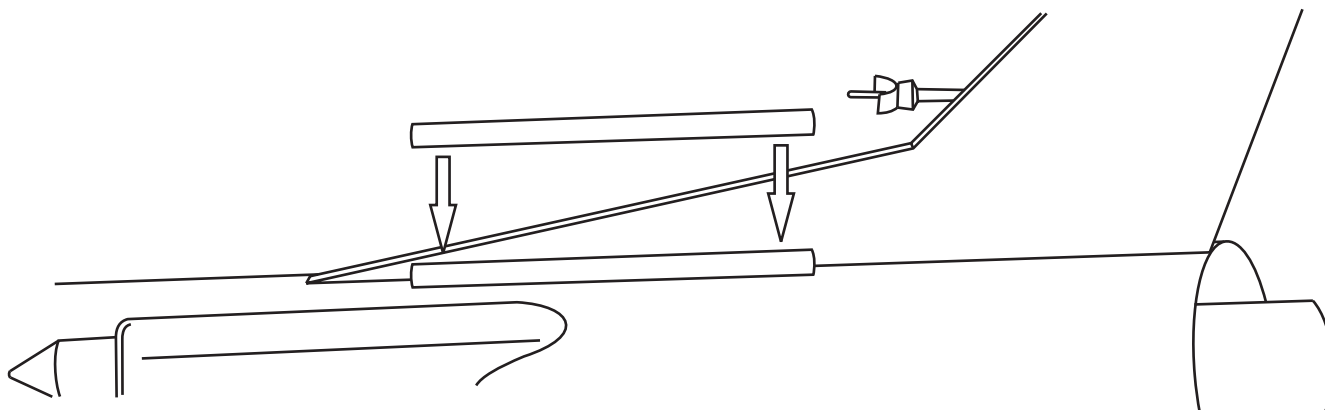

26. Glue the 4" x 3/16" Launch Lug (Z) to the underside of the rocket. Glue it to the wing / body tube joint. The front of the lug is against the leading edge of the wing.

27. The Shock Cord (MM) is attached to the upper body tube using a standard Tri-Fold Mount. Recess the mount 2" from the front of the tube to clear the nose cone.

Divide the shock cord into thirds. Tie a 1" loop in the Shock Cord 2/3 down from the top of the body tube. Tie the Snap Swivel and Parachute (SS) to the loop.

Tie the end of the Shock Cord to the Screw eye in the Nose Cone.

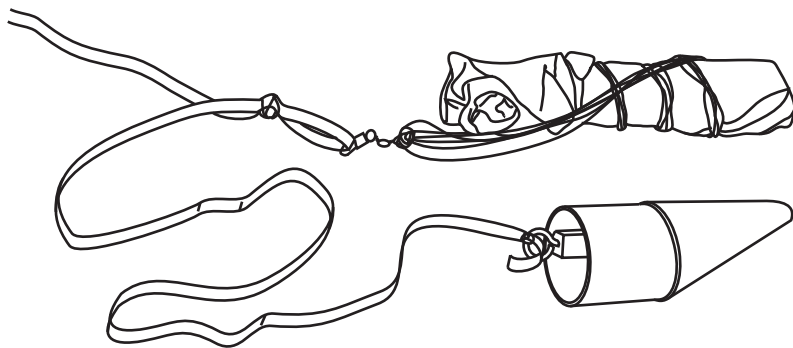

SURPRISE PARTS:

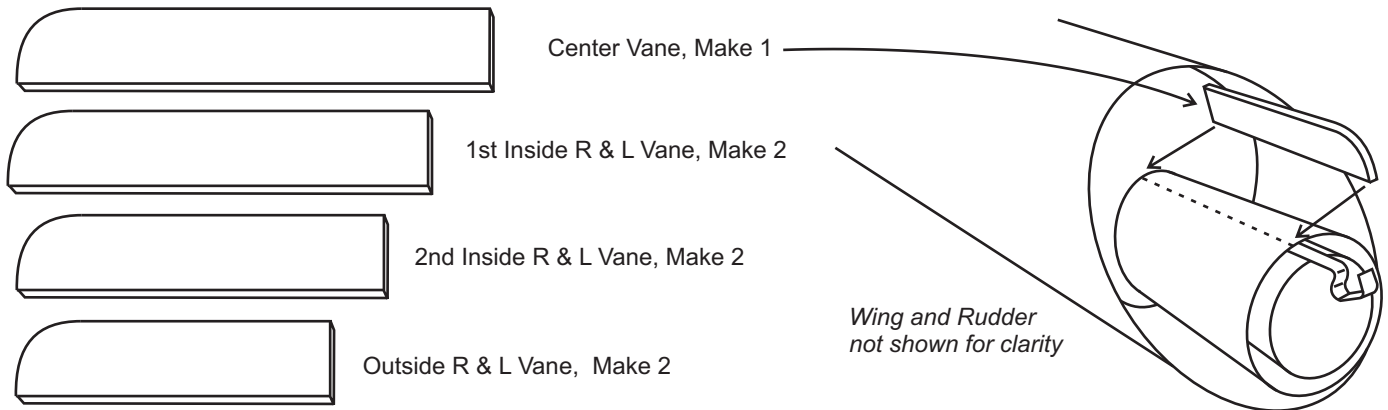

25. REQUIRED SURPRISE PARTS (4 Popsicle Sticks)

ENGINE COOLANT VANES: Cut out the vanes from Popsicle Sticks using the patterns. You'll need 1 center piece, and two each of the other sizes.

Glue the longest Center Piece against the offset Centering Ring and in line with the Engine Hook.

Glue the 1st Inside R & L Vanes on both sides of the Center Vane. Allow 3/16" space between the vanes.

Glue the 2nd Inside R & L Vanes on both sides of the Center Vane. Allow 3/16" space between the vanes.

Glue the Outside R & L Vanes on both sides of the Center Vane. Allow 3/16" space between the vanes.

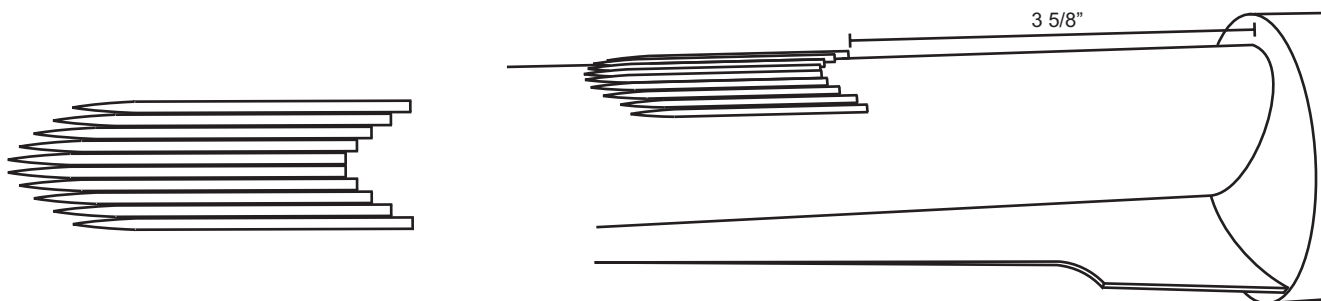

26. REQUIRED SURPRISE PARTS (10 Toothpicks)

DECORATIVE "PIPING": Cut 10 Toothpicks to 2" lengths. They are glued to the front - top of the BT-55 mid-section in an arc shape. Check the Pattern Sheets for the arc shape gluing pattern.

27. ADDITIONAL SURPRISE PARTS BONUS (3 Coins)

NOSE WEIGHT: I added three dimes into the clay weight in the nose cone. (See page 5)

28. FINISHING: After fillets and filling the model was spray painted white overall. The Engine Coolant Vanes were painted white off the model. The engine area was sprayed black. Then the Vanes were glued in place as it would be hard to mask easily.

Most of the decorative decals were lifted from the USPS Priority Mail box that all the parts were shipped in.

With a razor blade, lightly score around a desired piece of type or art. Lift the outer printed layer with your hobby knife. There will be some cardboard and glue left of the back of the top layer.

Lightly wet the back of the lifted art. Lightly scrape off the loosened glue and cardboard with a razor blade. Glue the art over the painted surfaces with a thin coat of white glue.

The first launch is scheduled for June 13, 2009 with a D12-3 engine.

USPS EXPRESS

Page 1, Templates and Patterns

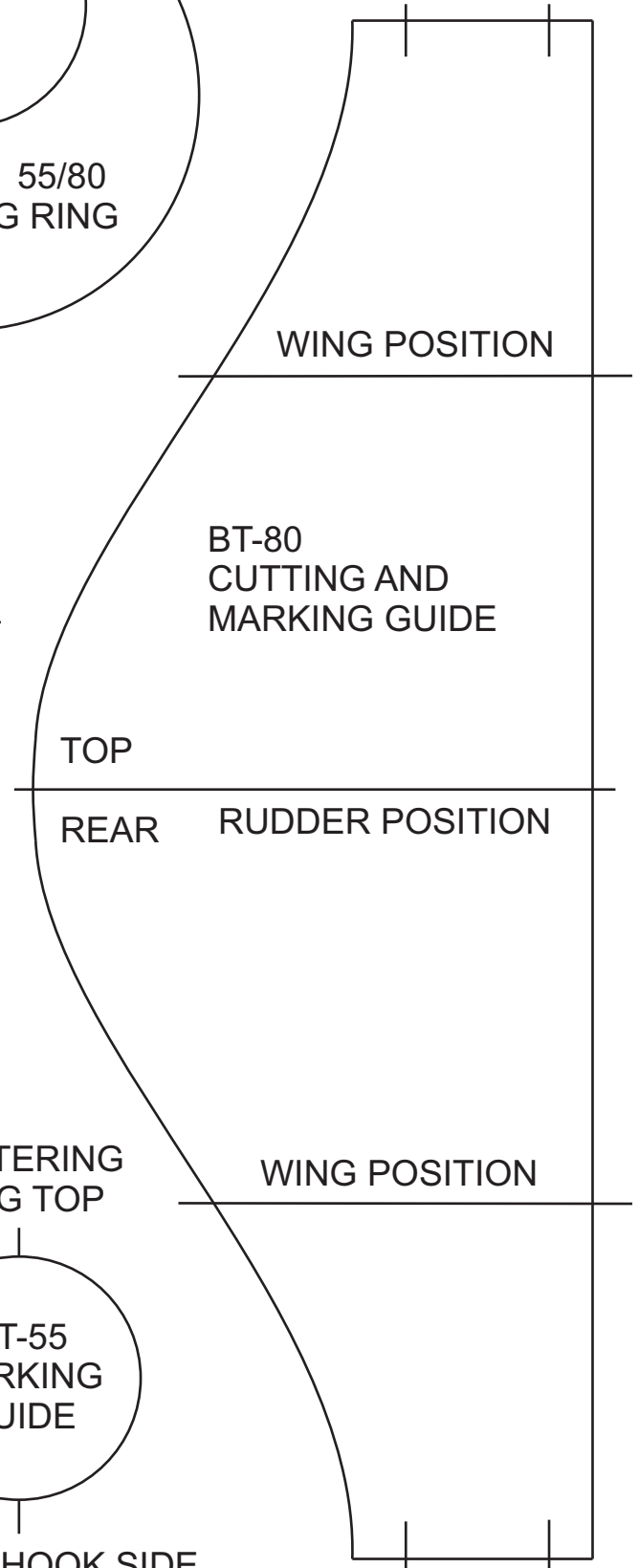
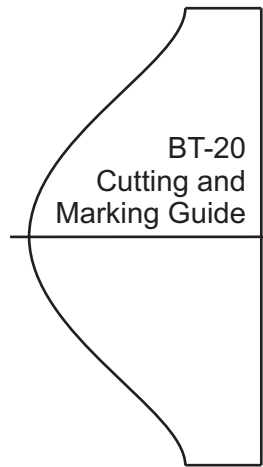
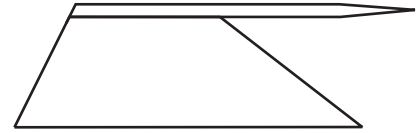
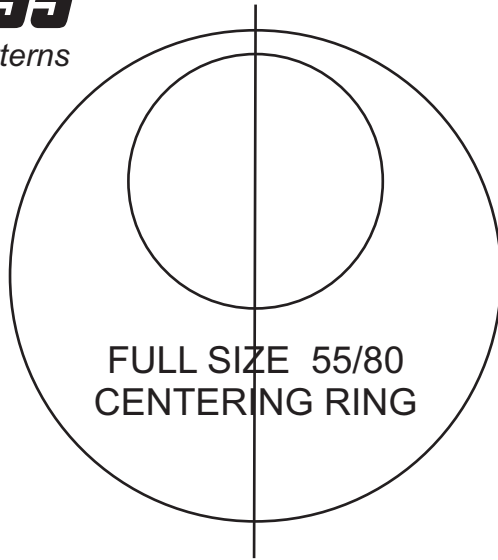
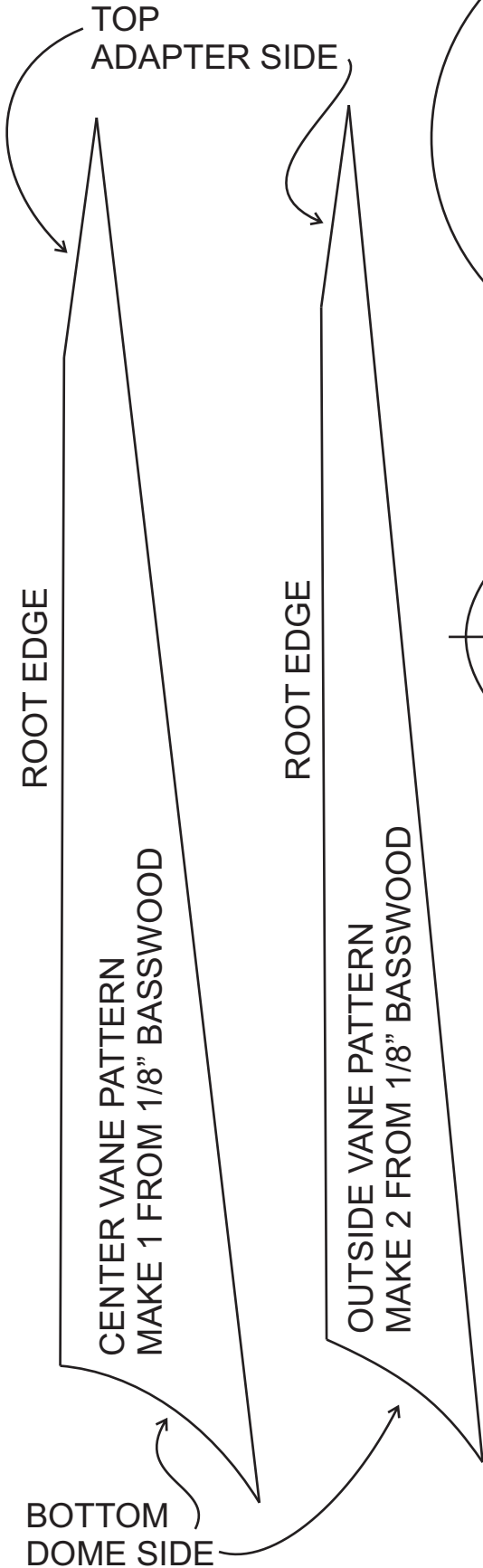

BT-55 Marking Guide	Side Vane Left	Center Vane (Center Bottom)	Side Vane Right
---------------------------	----------------	--------------------------------	-----------------

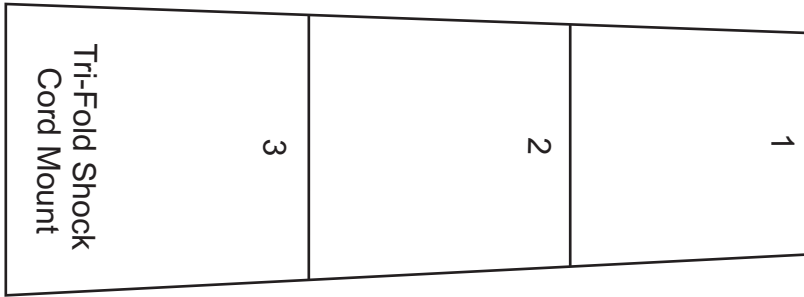

DECORATIVE
"PIPES"
10 Toothpicks
Cut to 2" long

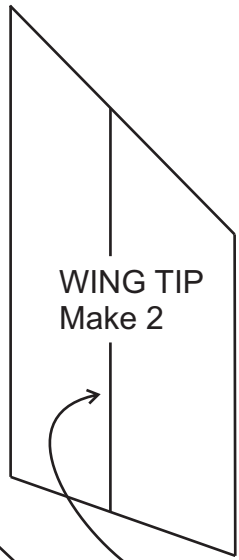
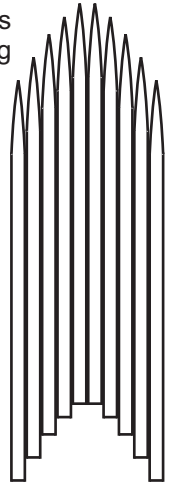

Centerline
Glues to
Wing Tip

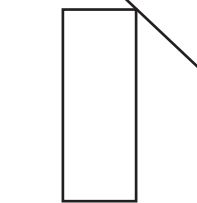

WING PATTERN
Make 2

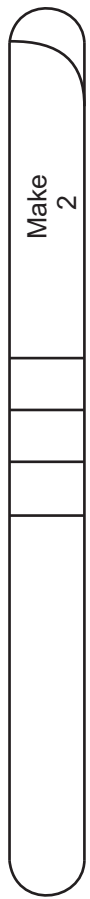
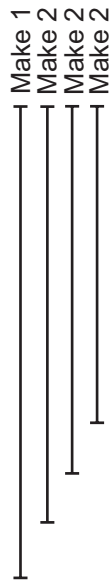

Rear
Engine
Van
es
Popsicle
Stick
Pattern

Make 2
Make 2
Make 1

RUDDER
"V" TIPS
Make 2

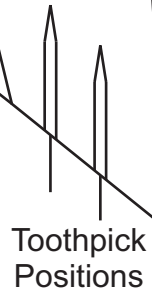

RUDDER PATTERN
Make 1

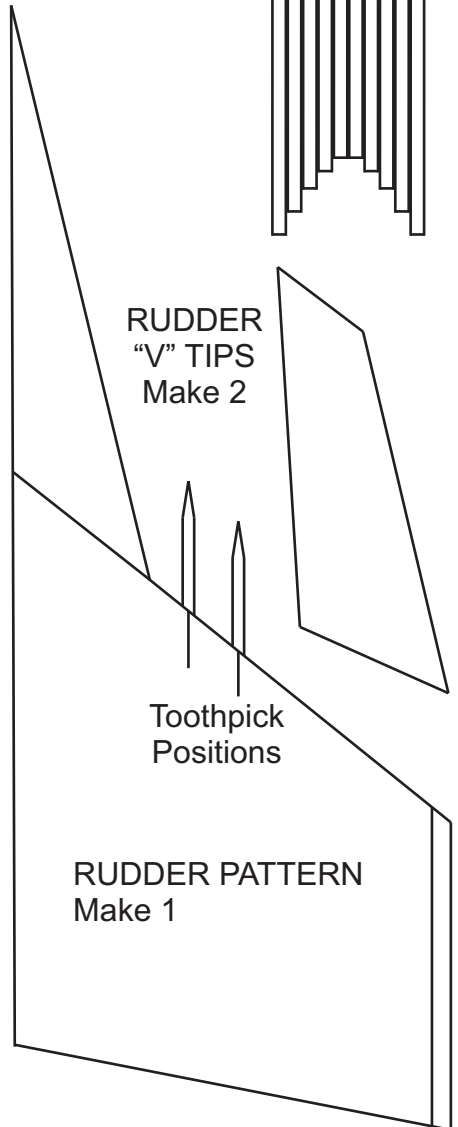

Rudder Top Angle Profile

